

## 915nm 200W High Power High Brightness Fiber Coupled Diode Laser K915FN1RN-200.0W

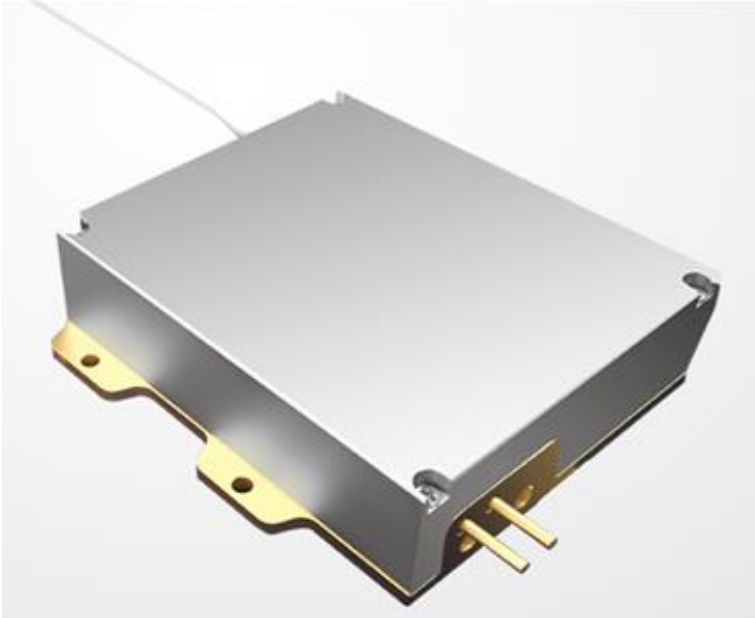

### Features:

- ◆ 915nm wavelength
- ◆ 200W output power
- ◆ 106.5 $\mu$ m fiber core diameter
- ◆ 0.22N.A.
- ◆ 1040nm-1200nm feedback protection

### Applications:

- ◆ Fiber laser pumping

BWT Beijing's High Power Diode Laser Modules are manufactured by adopting specialized fiber-coupling techniques, resulting in volume products with a high efficiency, stability and superior beam quality. The products are achieved by transforming the asymmetric radiation from the laser diode chip into an output fiber with small core diameter by using special micro optics. Inspecting and burn-in procedures in every aspect come to a result to guarantee each product with the reliability, stability and long lifetime.

Our research staffs are constantly improving and innovating the processing technology in the producing process, based on the professional knowledge and experience accumulated in long-terms. We are also continuously developing new products to meet customers' specific needs.

At BWT Beijing, to provide high quality products with reasonable price is our always goal.

## 915nm 200W High Power High Brightness Fiber Coupled Diode Laser K915FN1RN-200.0W

Specifications(25°C)		Symbol	Unit	K915FN1RN-200.0W		
				Minimum	Typical	Maximum
Optical Data	CW-Output Power	$P_o$	W	200	-	-
	Center Wavelength	$\lambda_c$	nm	915±10nm		
	Spectral Width (FWHM)	$\Delta\lambda$	nm	6		
	Wavelength Shift with Temperature	$\Delta\lambda/\Delta T$	nm/°C	-	0.3	-
	Wavelength Shift with Current	$\Delta\lambda/\Delta I$	nm/A	-	1	-
	Power in 0.15NA/0.22NA		%	-	90%	-
Electrical Data	Electrical-to-Optical Efficiency	PE	%	-	45	-
	Operating Current	$I_{op}$	A	-	15	16
	Threshold Current	$I_{th}$	A	-	0.8	-
	Operating Voltage	$V_{op}$	V	-	29	32
	Slope Efficiency	$\eta$	W/A	-	12	-
Fiber Data	Core diameter	$D_{core}$	μm	-	106.5	-
	Cladding diameter	$D_{clad}$	um	-	125	-
	Numerical Aperture	N.A.	-	-	0.22	-
	Total Fiber Length	$L_f$	m	1.9	2.0	-
	Fiber Loose Tubing Diameter/Length	-	μm	0.9mm PTFE /180cm		
	Minimum Static Bending Radius	-	mm	50	-	-
	Fiber termination	-	-	-	None	-
Feedback Isolation	Wavelength Range	$\lambda$	nm	1040~1200		
	Isolation	-	dB	-	30	-
Others	ESD	$V^{ESD}$	V	-	-	500
	Storage Temperature (Non-operating)	$T^{st}$	°C	-20	-	70
	Lead Soldering Temp	$T^{ls}$	°C	-	-	260
	Lead Soldering Time	t	sec	-	-	10
	Operating Case Temperature	$T^{op}$	°C	15	-	35
	Relative Humidity	RH	%	15	-	75

(1) Data measured under operation output at 200W@25°C.

(2) Operating temperature defined by the package case. Acceptable operating range is 15 - 35C, but performance may vary.

(3) A non-condensing environment is required for operation and storage conditions are from -20 to +70 °C with relative humidity between 15 to 75 %.

## 915nm 200W High Power High Brightness Fiber Coupled Diode Laser K915FN1RN-200.0W

### Package Dimensions (mm)

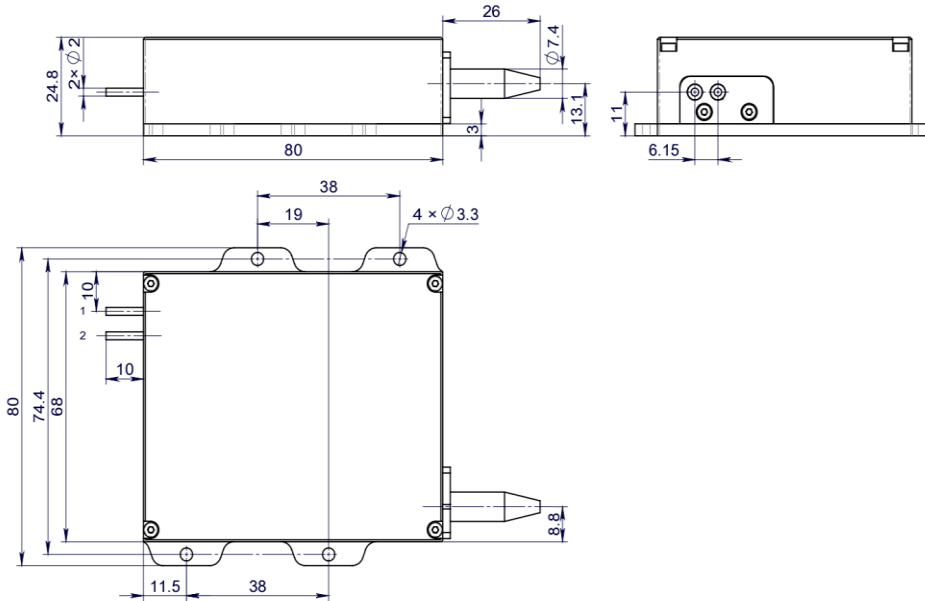

Pin	Function
1	LD (+)
2	LD (-)

### OPERATING NOTES

- ◆ ESD protection measures must be taken during storage, transportation and operation.
- ◆ Solder pins instead of using socket for electrical connections for modules with operating current higher than 6A. Soldering temperature should be lower than 260°C and soldering duration should be less than 10 seconds.
- ◆ Make sure the fiber output end is properly cleaned before operation of laser. Follow safety protocols to avoid injury when handling and cutting the fiber.
- ◆ Fiber bending radius should be bigger than 60mm to avoid leaking of laser light.
- ◆ Diode laser should be operated according to the specification. Over-drive the diode laser will reduce its lifetime.
- ◆ Avoid eye and skin exposure to direct radiation during operation.
- ◆ Use constant current power supply. Current surge may damage the laser.
- ◆ Diode laser must be operated under good cooling condition.





[www.bwt-bj.com](http://www.bwt-bj.com)

## 915nm 200W High Power High Brightness Fiber Coupled Diode Laser K915FN1RN-200.0W

---

**Declaration:** information and specifications contained herein are deemed to be reliable and accurate. BWT Beijing reserves the right to change, alter or modify the design and specifications of these products at any time without notice.18-1

Tel: +86-10-8368 1053

Fax: +86-10-8368 2949

E-mail: [sales@bwt-bj.com](mailto:sales@bwt-bj.com)

URL: [www.bwt-bj.com](http://www.bwt-bj.com)